

This specification describes the situation of the Proximus network and services. It will be subject to modifications for corrections or when the network or the services will be modified. Please take into account that modifications can appear at any moment. Therefore, the reader is requested to check regularly with the most recent list of available specifications that the document in one's possession is the latest version.

Proximus can't be held responsible for any damages due to the use of a version of this specification which is not included in the most recent list of available specifications (list always available with a request to the e-mail address mentioned in the underneath paragraph).

Whilst every care has been taken in the preparation and publication of **this document**, errors in content, typographical or otherwise, may occur. If you have remarks concerning its accuracy, please send a mail to the following address Proximus.uni.spec@Proximus.be and your remark will be transmitted to the right Proximus department.

The User Network Interface Specifications published via Internet are available for your information but have no official value. The only documents with an official value are printed on a specific paper.

If you want **to get an official version of this User Network Interface Specification**, please order it by sending your request by mail to Proximus.uni.spec@Proximus.be

Multi-Fractional STM-1 digital leased lines

Table of Contents

0.	DOCUMENT HISTORY.....	1
1.	INTRODUCTION	2 2
	CONNECTION CHARACTERISTICS.....	4
2.1.	Common characteristics of VC-4, VC-3 & VC-12 leased line connections.....	4
2.1.1.	Tolerance of VC timing	4
2.1.2.	Transfer delay.....	4
2.1.3.	Jitter	4
2.2.	Specific characteristics of a VC-4 leased line connection	5
2.2.1.	Information transfer susceptance	5
2.2.2.	Performance objectives	5
2.3.	Specific characteristics of a VC-3 leased line connection	6
2.3.1.	Information transfer susceptance	6
2.3.2.	Performance objectives	6
2.4.	Specific characteristics of a VC-12 leased line connection	7
2.4.1.	Information transfer susceptance	7
2.4.2.	Performance objectives	8
2.5.	Other used transmission systems.....	8
3.	NETWORK INTERFACE PRESENTATION	9
3.1.	The NTP (STM-1 interface).....	9
3.1.1.	Physical section layers	10
3.1.2.	STM-1 regenerator and multiplex section layers.....	11
3.1.3.	Path layer functions	12
3.1.4.	Safety.....	12
3.1.5.	ElectroMagnetic Compatibility (EMC).....	12
3.1.6.	TU/VC numbering scheme	13
3.2.	PDH interfaces	13
3.2.1.	2 Mbit/s	13
3.2.2.	34 Mbit/s	13
3.2.3.	140 Mbit/s	14
4.	TERMINAL EQUIPMENT.....	15
	ANNEX 1	16
	ANNEX 2	17

0. Document history

Every update of this document results in a complete new version with new version number and release date.

Version	Date	Main or important changes since previous version
1.0	10 JUL 2002	<ul style="list-style-type: none">• First version

1. Introduction

This document contains the *technical specifications* for the Proximus multi-fractional STM-1 digital leased line *service*.

This new service intends to reproduce the concept of the multi-fractional E1 (Nx64k on a 2 Mbit/s interface) for 2 Mbit/s services, 34 Mbit/s services and 140 Mbit/s services. These 2, 34 or 140 Mbit/s end-to-end leased lines terminate on a STM1 interface.

The multi-fractional STM1 digital leased line (MFSTM1) provides a bidirectional point-to-point digital connection with an information transfer rate of 2048 kbit/s and/or 34 Mbit/s or 140 Mbit/s within a STM1 frame in accordance with ITU-T Recommendation G.707.

The network interface presentation offered to a MFSTM1 leased line customer is based on the G957-interface.

The rules applied by PROXIMUS for interfacing the customer's equipment with the PROXIMUS SDH network are based on the G.707 and G.957 ITU-T recommendations. Electrical or optical interfaces can be used depending on the service type. The network cabling follows the standard Proximus rules.

Customer interface	Proximus interface
VC12 or 2 Mbps	electrical STM-1 / G.703 @ 155.520 Mbps optical STM-1 / G.957 @ 155.520 Mbps
VC3 or 34 Mbps	electrical STM-1 / G.703 @ 155.520 Mbps optical STM-1 / G.957 @ 155.520 Mbps
VC4 or 140 Mbps	electrical STM-1 / G.703 @ 155.520 Mbps optical STM-1 / G.957 @ 155.520 Mbps
Connectors	
Electrical	DIN 1.6/5.6 CEI 169-13 75 Ohms
Optical	Optoclip II connectors
Optical fiber	
STM-1	L1-1 1300 nm L1-2 1550 nm

These leased line specifications are based on a generic model as shown in figure 1.

The SDH connection is presented to the customer via an "interface presentation" at the Network Termination Point (NTP) which comprises all physical connections and their technical access specifications that form part of the Proximus SDH leased line network.

The PDH connection is presented to the customer via an "interface presentation" at the End Point (EP) which comprises all physical connections and their technical access specifications

On one end, the NTP is presented to the customer terminal equipment. On the other end, we have an SDH equipment with cross-connection capability offering: either PDH signals (n*2 Mb, n*34 Mb or 140 Mb), either different combination of VC-n (n = 12, 3 or 4) transported by different STM-1 connections to different customer equipment (NTP).

This connection includes a series of transmission channels or telecommunication circuits, providing the point-to-point transfer of signals between the terminal equipment of the customer or between the terminal equipment of the customer and the terminal equipment of Proximus.

The NTP is also the point at which the terminal equipment of the customer is attached to the SDH leased line offering an STM-1 interface. ; the attachment requirements for the customer's terminal equipment are also mentioned in this document.

Throughout this document, reference is made to several national and international standards; details of these publications are given in annex 2. In addition, the list of the abbreviations which apply to this document, can be found in annex 1.

**Generic model for
Multi-Fractional STM-1 Leased
Line Specifications**

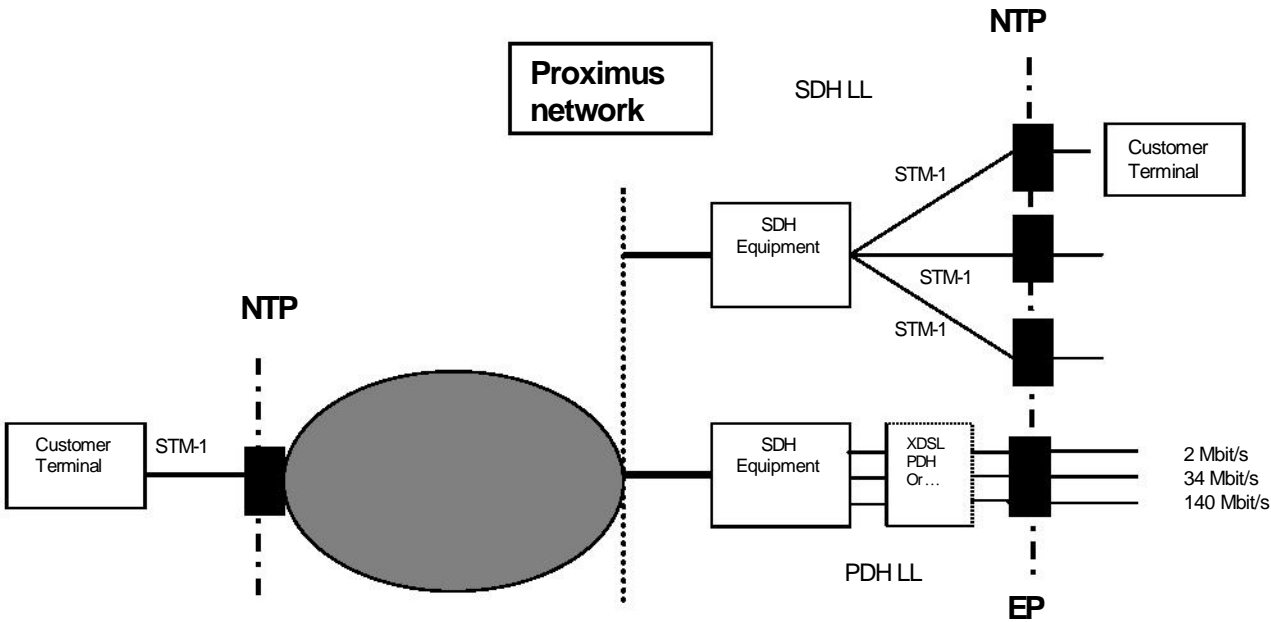

Figure 1

The drawing represents point-to-point or point to multi-point circuits transporting SDH and/or PDH client signals.

2. Connection characteristics

The SDH leased line provides a bi-directional and symmetrical leased line connection of SDH virtual containers, i.e. VC-4, VC-3 and VC-12, which are transferred transparently throughout the Proximus network, except the N1/N2 byte.

Signals transmitted across the SDH leased line connections, are subject to restrictions and to impairments such as transfer delay, jitter, wander, etc. This paragraph defines the technical specifications for the bi-directional and symmetrical leased line connections of SDH virtual containers, i.e. VC-4, VC-3 and VC-12.

2.1. Common characteristics of VC-4, VC-3 & VC-12 leased line connections

2.1.1. Tolerance of VC timing

The SDH leased line connection shall carry the customer timing with a tolerance of ± 20 ppm (G.783 § 9.3.1.2).

2.1.2. Transfer delay

The one way end-to-end delay of the SDH leased line is less than $(10 + 0,005G)$ ms, where G is the length of the optical fibre in kilometers. If this length is unknown, the one way end-to-end delay of the SDH leased line is less than $(10 + 0,01G)$ ms, where G is the geographical distance in kilometers.

2.1.3. Jitter

The SDH leased line connection shall operate as specified in this document when the jitter at the leased line input is within the limits given in paragraph 3 ("Network interface presentation").

2.2. Specific characteristics of a VC-4 leased line connection

2.2.1. Information transfer susceptance

- The VC-4 leased line connection shall be capable of transferring transparently a complete and bi-directional VC-4 except the N1-byte, provided that the VC-4 is generated according to the specifications mentioned in paragraph 4 ("terminal equipment").
- The structure of a VC-4 is shown in figure 2. The bytes of a VC-4 are transmitted with a frequency of 8 kHz; i.e. the frame length is 125 μ s.

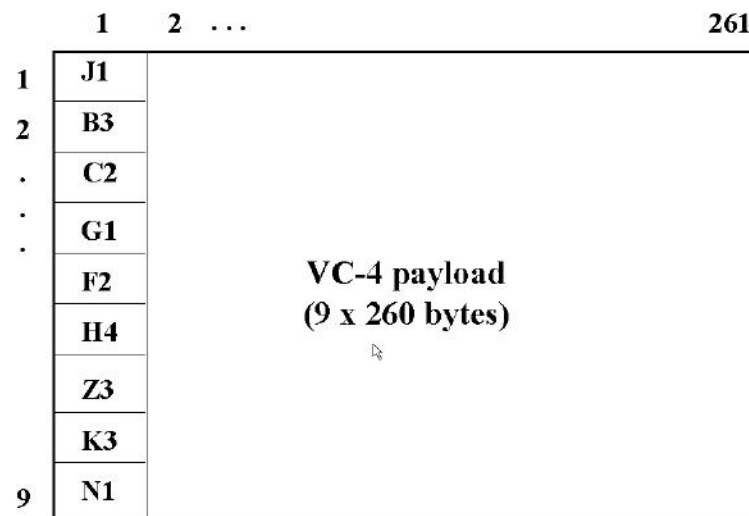

Figure 2

Note: the content of the B3 byte may change at Proximus tandem connection monitoring processes; however, the integrity of B3 parity information is maintained through the VC-4 leased line connection.

- An AU-4-AIS shall occur at the far end output of the VC-4 leased line connection when a defect occurs along the SDH leased line connection or at the leased line input. [AU-4-AIS is a STM-N signal in which the entire capacity of an Administrative Unit 4 (AU-4) is set to logic "1".]

2.2.2. Performance objectives

- The error performance level of a VC-4 leased line connection is specified in terms of errored seconds, severely errored seconds and background block errors; these performance parameters are as those defined in ITU-T Recommendation G.826.

2.3. Specific characteristics of a VC-3 leased line connection

2.3.1. Information transfer susceptance

- The VC-3 leased line connection shall be capable of transferring transparently a complete and bi-directional VC-3, except the N1-byte.
- The structure of a VC-3 is shown in figure 3. The bytes of a VC-3 are transmitted with a frequency of 8 kHz; i.e. the frame length is 125 μ s.

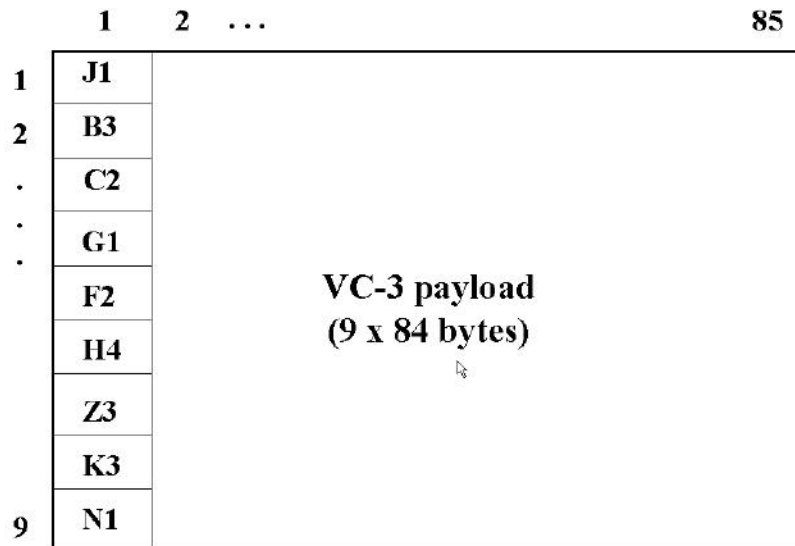

Figure 3

Note: the content of the B3 byte may change at Proximus tandem connection monitoring processes; however, the integrity of B3 parity information is maintained through the VC-3 leased line connection.

- A TU3-AIS shall occur at the far end output of the VC-3 leased line connection when a defect occurs along the SDH leased line connection or at the leased line input. [TU3-AIS is a STM-N signal in which the entire capacity of a TU-3 is set to logic "1".]

2.3.2. Performance objectives

- The error performance level of a VC-3 leased line connection is specified in terms of errored seconds, severely errored seconds and background block errors; these performance parameters are as those defined in ITU-T Recommendation G.826.

2.4. Specific characteristics of a VC-12 leased line connection

2.4.1. Information transfer susceptance

- The VC-12 leased line connection shall be capable of transferring transparently a complete and bi-directional VC-12, except the N2-byte.
- The structure of a VC-12 is shown in figure 4. The bytes of a VC-12 are transmitted with a frequency of 2 kHz; i.e. the frame length is 500 μ s.

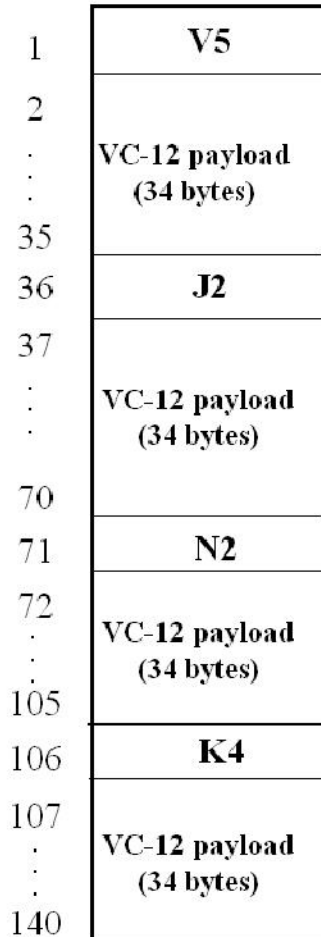

Figure 4

Note: the content of the bits 1 and 2 of the V5-byte may change at Proximus tandem connection monitoring processes; however, the integrity of the parity information BIP-2 is maintained through the VC-12 leased line connection.

- A TU12-AIS shall occur at the far end output of the VC-12 leased line connection when a defect occurs along the SDH leased line connection or at the leased line input. [TU12-AIS is a STM-N signal in which the entire capacity of a TU-12 is set to logic "1".]

2.4.2. Performance objectives

- The error performance level of a VC-12 leased line connection is specified in terms of errored seconds, severely errored seconds and background block errors; these performance parameters are as those defined in ITU-T Recommendation G.826.

2.5. Other used transmission systems

In the access part, another technology than SDH can be used to transport the PDH signals such as PDH, xDSL, ...

3. Network interface presentation

3.1. The NTP (STM-1 interface)

The SDH leased line connection is presented to the customer via interfaces at the Proximus Network Termination Points (NTP). This paragraph specifies the NTP technical characteristics; it defines its specifications for the physical section layer, the regenerator & multiplex section layers, and the SDH path layers.

In principle, the NTP of the SDH leased line will be provided with a STM-1 interface, complying with the ITU-T Recommendations G.707 and G.783. Its multiplex structure (see figure 5) is in accordance with ETS 300 147 and ITU-T Recommendation G.707.

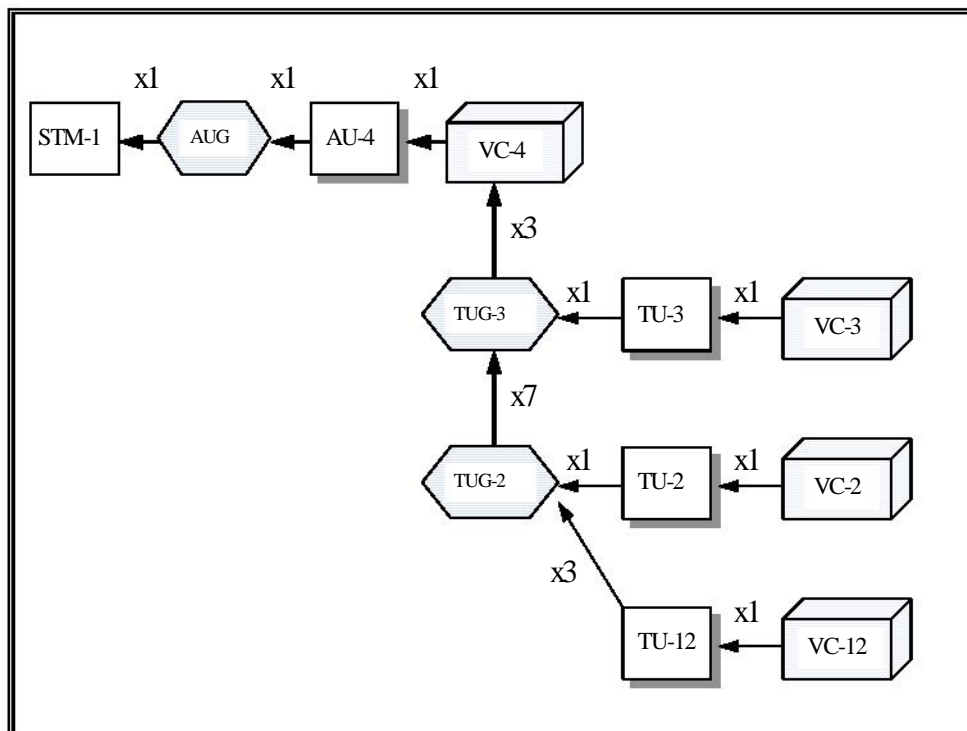

Figure 5

3.1.1. Physical section layers

Dependent on the customer's choice, the NTP of the SDH leased line shall be provided with one of the following interfaces:

- STM-1 electrical interface;
- STM-1 optical interface at 1310 nm.

3.1.1.1. STM-1 electrical interface

- The electrical characteristics of this SDH leased line NTP comply with ITU-T Recommendation G.703 (paragraph 12) and with ETS 300 166.
- The SDH leased line NTP, equipped with an electrical STM-1 interface, shall be provided with two coaxial 75 ohms sockets, one each for transmit and receive. These interface connectors are 1,5/5,6 type sockets complying with IEC 169-13. The outer conductor of the coaxial pair shall be connected to signal ground both at the input and at the output port.
- The physical section layer functions of the SDH leased line NTP, equipped with a STM-1 electrical interface, are in accordance with ETS 300 417-2-1.
- The jitter and wander tolerance of the SDH leased line input port, as well as the output jitter and wander generation at the NTP are in accordance with ITU-T Recommendation G.825.

3.1.1.2. STM-1 optical interface

- The optical characteristics of the SDH leased line NTP, equipped with a STM-1 optical interface, are in accordance with ITU-T Recommendation G.957; this SDH leased line NTP interface is designed for operation on *single-mode* optical fibres.
- The physical section layer functions of the SDH leased line NTP, equipped with an STM-1 optical interface, are in accordance with ETS 300 417-2-1.
- The jitter and wander tolerance of the SDH leased line input port, as well as the output jitter and wander generation at the NTP are in accordance with ITU-T Recommendation G.825.
- The SDH leased line NTP, equipped with an optical STM-1 interface, shall be provided with two optical sockets, one each for transmit and receive.

The STM-1 boards are connected to the optical fibre. This fibre is terminated onto an optical distribution frame (OSDF, OMDF or cable head).

The optical connectors that have to be mounted on the fibre cord relaying the optical distribution frame are of the type Optoclip 2.

The Optoclip 2 connectors have the following characteristics:

- attenuation (25°C) :
 - Less than to 0.3 dB.
 - Mean value (measurement on more than 10 samples): < 0.25 dB.
 - After 200 connections/disconnections (15°<T<35°): < 0.4 dB and mean value (measurement on more than 10 samples): < 0.35 dB.
- Return loss :
 - More than 50 dB.
 - Mean value (measurement on more than 10 samples): more than 54 dB.
- Thermal behaviour :
 - Variation in attenuation between -20°C and 50°C: less than 0.004 dB/°C. -
 - Mean value (measurement on more than 10 samples): < 0.003 dB/°C.

3.1.2. STM-1 regenerator and multiplex section layers

- The STM-1 regenerator and multiplex section layers of the SDH leased line network interface comply with ETS 300 417-3-1.
- As the STM-1 signal of the SDH leased line network interface complies also with ITU-T Recommendation G.707, regenerator and multiplex Section OverHead (SOH) information is added to the customer's information payload to create the STM-1 signal.

The rows 1-3 of the SOH are designated as Regenerator Section OverHead (RSOH) while rows 5-9 are designated to be Multiplex Section OverHead (MSOH). This is illustrated in figure 6. The definitions of the SOH bytes (such as A1, A2, JO,...) are mentioned in ITU-T Recommendation G.707.

Currently, the unmarked bytes in the SOH of figure 6, are undefined.

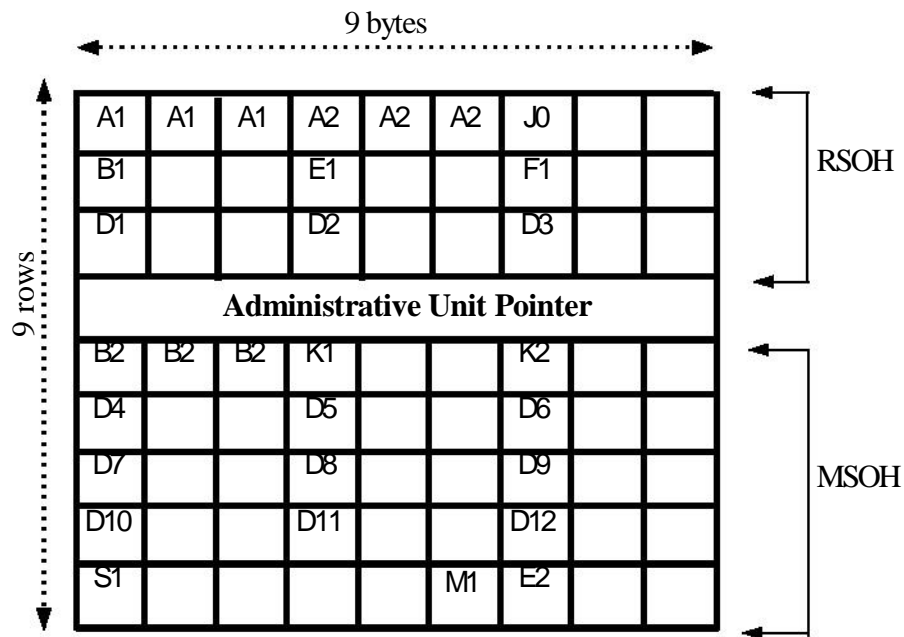

Figure 6

- Regarding the SOH bytes of the SDH leased line network interface, an overview of their functionalities is given in table 1. Just to be clear, the following definitions apply:
 - * **required**: these signals at the interface shall contain valid information as defined by ITU-T Recommendation G.707.
 - * **optional**: valid information may or may not be present in these signals; as a consequence, the use of these functions shall be mutually agreed by the customer and Proximus.
 - * **not applicable**: this function is not defined at the interface; as a consequence, the customer's terminal and the SDH leased line NTP have to be capable of functioning properly with an incoming STM-1 signal programmed with this "undefined" SOH byte.

SOH-byte	functionality requirement	Remarks
A1-A2	required	
JO	optional	By mutual agreement between Proximus and the customer a Section Access Point Identifier may be used, conform to ITU-T Recommendation G.707.
B1	required	
E1, E2	not applicable	
F1	not applicable	
D1-D12	not applicable	
B2	required	
K1 & K2(bits 1-5)	not applicable	
K2(bits 6-8)	required	MS-RDI is used for MS-FERF and MS-AIS.
S1 (bits 5-8)	required	
M1	optional	
other bytes	not applicable	

Table 1

3.1.3. Path layer functions

- The path layer forms the end-to-end connection of the SDH leased line. Three types of VCs are offered by the Proximus SDH leased line service, namely: VC-4, VC-3 and VC-12. The formats of these VCs are defined in ETS 300 147 and ITU-T Recommendation G.707. Each VC-n includes a payload and a path overhead (POH).
- The path layers of the SDH leased line network interface comply with ETS 300 417-4-1. However, please note that the path overhead of a VC-n, transmitted across the SDH leased line connection, has to be generated and terminated by the customer's terminal equipment. The Proximus SDH leased line shall transport these virtual containers *transparently, except the network operator byte N1/N2*:
 - ⇒ The N1-byte could be used by Proximus to determine the quality of the received and transmitted VC-4 or VC-3 path signals. The content of the B3-byte may change at the Proximus tandem connection monitoring processes; however, the integrity of the parity information of the B3-byte will be maintained through the Proximus SDH leased line.
 - ⇒ The N2-byte could be used by Proximus to determine the quality of the received and transmitted VC-12 path signals. The content of the V5-byte (bits 1 & 2) may change at the Proximus tandem connection monitoring processes; however, the integrity of the parity information of the BIP-2 will be maintained through the SDH leased line.

3.1.4. Safety

The SDH leased line NTP complies with the requirements for accessible parts of a SELV circuit (in accordance with EN 60950).

3.1.5. ElectroMagnetic Compatibility (EMC)

The NTP complies with the EMC requirements which are imposed under the EMC Directive (89/336/EEC).

3.1.6. TU/VC numbering scheme

The numbering of TU-12s (VC-12s) and TU-3s (VC-3s) in a VC-4 is specified in subclause 3.3 of ETS 300 417-1-1; the allocation of these numbers is defined by means of a three figures address (K, L, M) where K represents the TUG-3 number, L the TUG-2 number and M the TU-1 number.

The customer and Proximus have to use the above mentioned numbering scheme for his VC-n address, which has to be communicated to Proximus. By doing so, Proximus will be able to offer the customer an enhanced service for his SDH leased line.

3.2. PDH interfaces

Dependent on the customer's choice, the provided signals can be PDH signals (2, 34 or 140 Mbit/s).

3.2.1. 2 Mbit/s

3.2.1.1. Physical characteristics

The physical connection arrangements for the EP of the Proximus 2 Mbit/s leased line shall consist of one RJ-45 connector complying with ISO 8877 recommendation (120 Ohms version of the G.703-interface).

3.2.1.2. Electrical characteristics

The electrical characteristics of the EP of the Proximus 2048 kbit/s digital leased line are in accordance with ITU-T Recommendation G.703 (120 Ohms).

3.2.1.3. ElectroMagnetic Compatibility (EMC)

The network interface presentation fulfils to the EMC requirements which are imposed under the EMC Directive 89/336/EEC.

3.2.2. 34 Mbit/s

3.2.2.1. Physical characteristics

The physical connection arrangements for the EP of the Proximus 34 Mbit/s leased line (75 Ohms version of the G.703-interface) shall consist of two 1.6/5.6 coax-connectors (one coaxial pair in each transmission direction) complying with IEC 169-13.

3.2.2.2. Electrical characteristics

The electrical characteristics of the EP of the Proximus 34 Mbit/s digital leased line are in accordance with ITU-T Recommendation G.703 (75 Ohms).

3.2.2.3. ElectroMagnetic Compatibility (EMC)

The network interface presentation fulfils to the EMC requirements which are imposed under the EMC Directive 89/336/EEC.

3.2.3. 140 Mbit/s

3.2.3.1. Physical characteristics

The physical connection arrangements for the EP of the Proximus 140 Mbit/s leased line (75 Ohms version of the G.703-interface) shall consist of two 1.6/5.6 coax-connectors (one coaxial pair in each transmission direction) complying with IEC 169-13.

3.2.3.2. Electrical characteristics

The electrical characteristics of the EP of the Proximus 34 Mbit/s leased line are in accordance with ITU-T Recommendation G.703 (75 Ohms).

3.2.3.3. ElectroMagnetic Compatibility (EMC)

The network interface presentation fulfils to the EMC requirements which are imposed under the EMC Directive 89/336/EEC.

4. Terminal equipment

The technical characteristics of the customer's terminal interface have to be in line with the relevant ETSI and ITU-T specifications and recommendations.

In order to ensure that the interface of the client's terminal equipment is compatible with the transparent SDH leased line, Proximus has produced a document, specifying the customer's terminal attachment requirements for connection to the NTP of the Proximus SDH leased line. This document has the following references: "Transparent SDH leased lines; attachment requirements for terminal equipment interface".

Nevertheless, when PDH interfaces are offered to the customer, the network can also be terminated with other technologies than SDH (PDH, xDSL, ...).

At the NTP the customer shall provide Proximus with a grounding connection point. This grounding connection point should be easily accessible, located near the NTP, and shall enable Proximus to attach a 4 mm (minimum section) ground cable with lug, bolt and washer. The characteristics of the grounding connection point provided by the customer must be conform to article 69 of the actual RGIE ; this grounding point shall have a resistance value not exceeding 30 Ohms.

¹ RGIE: Règlement Général des Installations Electriques

ANNEX 1

Abbreviations

For the purpose of this document, the following abbreviations apply:

AIS	Alarm Indication Signal.
AU-n	Administrative Unit, level n.
AU-4-AIS	Administrative Unit (level 4) Alarm Indication Signal.
BBE	Background Block Errors.
BIP-N	Bit Interleaved Parity, width N.
EMC	ElectroMagnetic Compatibility.
ES	Errored Second.
ETS	European Telecommunication Standard.
ETSI	European Telecommunications Standards Institute.
I	International Telecommunication Union.
ITU-T	Multiplex Section Alarm Indication Signal.
MS-AIS	Multiplex Section Far End Receive Failure.
MS-FERF	Multiplex Section Remote Defect Indication.
MS-RDI	Multiplex Section OverHead. Network
MSOH	Termination Point.
NTP	Plesiochronous Digital Hierarchy. Path
PDH	Overhead. Parts per million.
POH	Réglement Général des Installations Electriques
ppm	Regenerator Section OverHead.
RGIE	Synchronous Digital Hierarchy.
RSOH	Safety Extra Low Voltage. Severely
SDH	Errored Second. Section Overhead.
SELV	Synchronous Transport Module, level N.
SES	Tributary Unit Group, level m. Tributary Unit,
SOH	level m.
STM-N	Tributary Unit, level m, Alarm Indication Signal.
TUG-m	Virtual Container, level n.
TU-m	
TU-m-AIS	
VC-n	

ANNEX 2

Reference list of standards

G.703	(4/91) Physical/electrical characteristics of hierarchical digital interfaces.
G.707	(3/96) Network node interface for the synchronous digital hierarchy (SDH).
G.783	(5/96) Characteristics of synchronous digital hierarchy (SDH) equipment functional blocks.
G.825	(3/93) The control of jitter and wander within digital networks which are based on the synchronous digital hierarchy (SDH).
G.826	(1996) Error performance parameters and objectives for international constant bit rate digital paths at or above the primary rate.
G.957	(7/95) Optical interfaces for equipment and systems relating to the synchronous digital hierarchy (SDH).
prETS 300 147	(11/96) Transmission and Multiplexing (TM); Synchronous Digital Hierarchy (SDH); Multiplexing structure.
ETS 300 166	(1993) Transmission and Multiplexing (TM); Physical and electrical characteristics of hierarchical digital interfaces for equipment using the 2048 kbit/s based plesiochronous or synchronous digital hierarchies.
ETS 300 417-1-1	(1996) Transmission and Multiplexing (TM); Generic functional requirements for Synchronous Digital Hierarchy (SDH) equipment, part 1: Generic processes and performance.
ETS 300 417-2-1	(1996) Transmission and Multiplexing (TM); Generic functional requirements for Synchronous Digital Hierarchy (SDH) equipment, part 2 : Physical section layer functions.
ETS 300 417-3-1	(1997) Transmission and Multiplexing (TM); Generic requirements of transport functionality of equipment; Part 3-1: Synchronous Transport Module-N (STM-N) regenerator and multiplex section layer functions.
ETS 300 417-4-1	(1997) Transmission and Multiplexing (TM); Generic requirements of transport functionality of equipment; Part 4-1: Synchronous Digital Hierarchy (SDH) path layer functions.
IEC 169-13	(1976) Radio frequency connectors - part 13.
IEC 874-13	(1993) Connectors for optical fibres and cables - part 13: sectional specification for fibre optic connector - type CF08.
EN 60950	(1992) Safety of information technology equipment including electrical equipment.